

1.Object:

Provide technical data of subject products for applications.

2.Scope:

RHN-5/

3.Conformity to Standards:

VDE 0660 BS EN 60947-4-1 UL 508 IEC 60947-4-1

JEM 1356 CNS C4084 JIS C8325

4.Performance, Specifications and Dimensions:

4.1Performance and Specifications:

Catalogue Number	RHN-5/ <input type="checkbox"/> <input type="checkbox"/>	
Rated Insulation Voltage (Ui)	UL 600V	<input type="checkbox"/> IEC 690V
Nominal Current Designation	0.45, 0.67 ,1, 1.5 ,2.1 ,2.7 ,3.6 ,5,6 ,8.5 ,12.5	
Current Setting Range	See item 5.	
Function	1. Open phase and overload protection 2. Temperature compensated 3. Test (STOP) function.	
Reset Mode	Automatic, Manual	
Contacts Configuration	1NO + 1NC	
<input type="checkbox"/> Temperature Compensation Range	-5 <input type="checkbox"/> ~ 40 <input type="checkbox"/>	
<input type="checkbox"/> Trip Class	10A	

<input type="checkbox"/> 2								Approved by	Checked by	Prepared by
<input type="checkbox"/> 1										
<input type="checkbox"/> 0	6	add subject			2001.12.10	-	-	-		
Sub-edition	No. of Change	Reason of Revision			Date	Approved by	Checked by	Revised by		
<input type="checkbox"/>	<input type="checkbox"/> → <input type="checkbox"/> → <input type="checkbox"/>									
1	1									

RHN-5/□ Thermal Overload Relay

Catalogue Number		RHN-5/□□	
Contact Capacities	AC-15	120V	6A
		240V	3A
		380V	1.9A
		480V	1.5A
		500V	1.4A
		600V	1.2A
	Ith	N.C. Contact	6A
		N.O. Contact	6A
Type of Terminal	Source Side	Pin	
	Load Side	Screw (M4)	
Applicable Contactors		CN-5/-6	

Note:(1) Maximum wire size applicable at load side of main terminal is AWG1 (8.4mm²)

(2) Maximum width applicable of crimp-type terminal at source side is 8mm.

RHN-5/□ Thermal Overload Relay

5.1 RHN-5 Applicable current range 0.3A-12.5A:

Motor Capacity (KW)					Applicable Thermal Relay		
Single-Phase Induction Motor		Three-Phase Induction Motor (V)			Current Setting	Nominal Current	Catalogue Number
110-120	220-240	220-240	380-415	440-480	Range (A)	Designation	
					0.3-0.45	0.45	RHN-5□□
				0.2	0.45-0.67	0.67	
			0.2	0.2,0.4	0.67-1	1	
	0.1	0.2	0.4	0.4,0.55	1-1.5	1.5	
	0.1	0.4	0.55,0.75	0.55,0.75	1.4-2.1	2.1	
0.1	0.2	0.4,0.55	0.75	0.75,1.1	1.8-2.7	2.7	
0.1	0.2,0.4	0.55,0.75	1.1,1.5	1.5	2.4-3.6	3.6	
	0.4,0.55	0.75,1.1	1.5	0.5,2.2	3.5-5.0	5	
0.2	0.55,0.75	1.1	2.2	2.2	4-6	6	
0.4	0.75	1.5	3.7	3.7	5.5-8.5	8.5	
0.55,0.75	1.1,1.5	2.2		5.5	8.5-12.5	12.5	

5.2. Overall Dimension:

RHN-5/□ Thermal Overload Relay

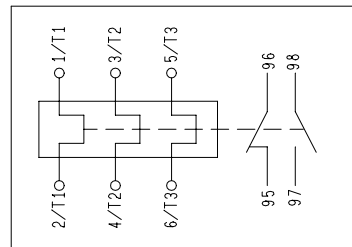
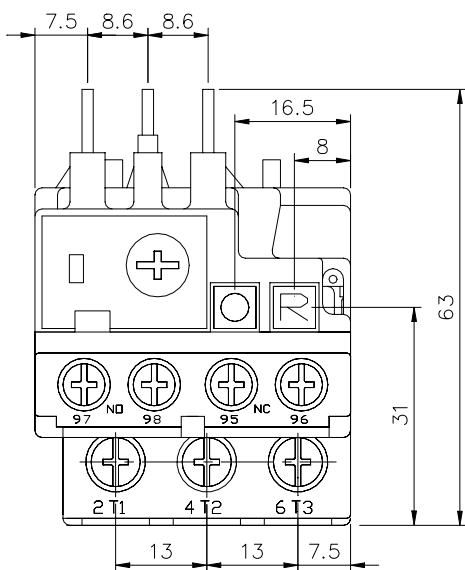

Terminal Marking

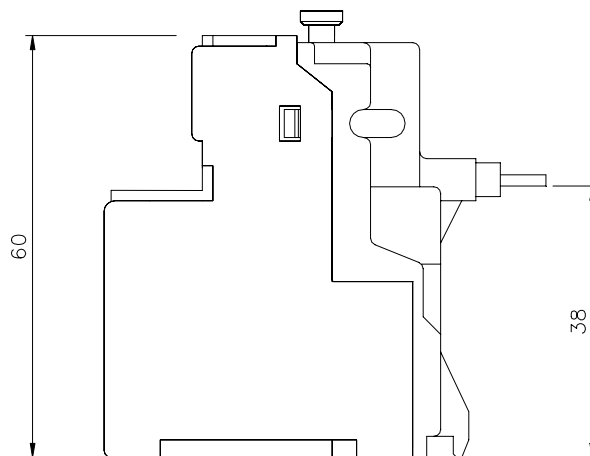
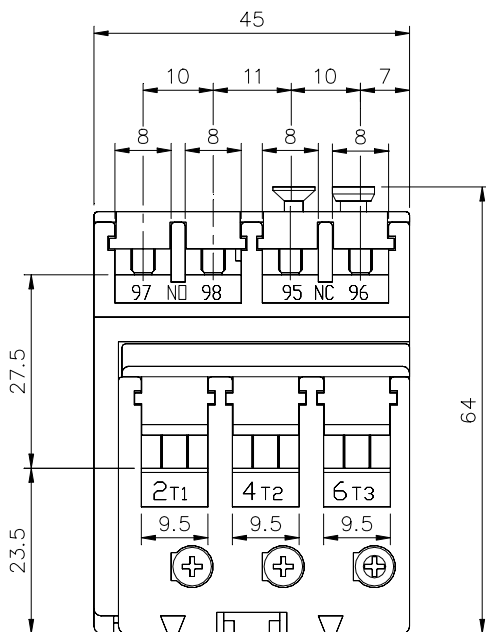

□

5.3. Tripping curve of thermal overload relays:

RHN-5/□ Thermal Overload Relay

Catalogue Number	RHN-5/0.45A
Current Designation (A)	0.45
Current Setting Range (A)	0.3~0.45

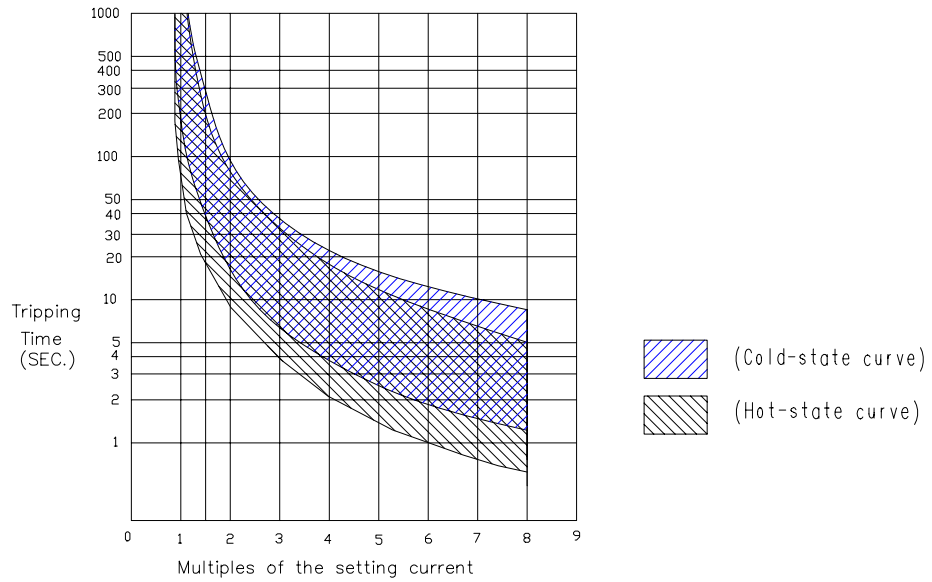

Single-Phase failure Protection Characteristic

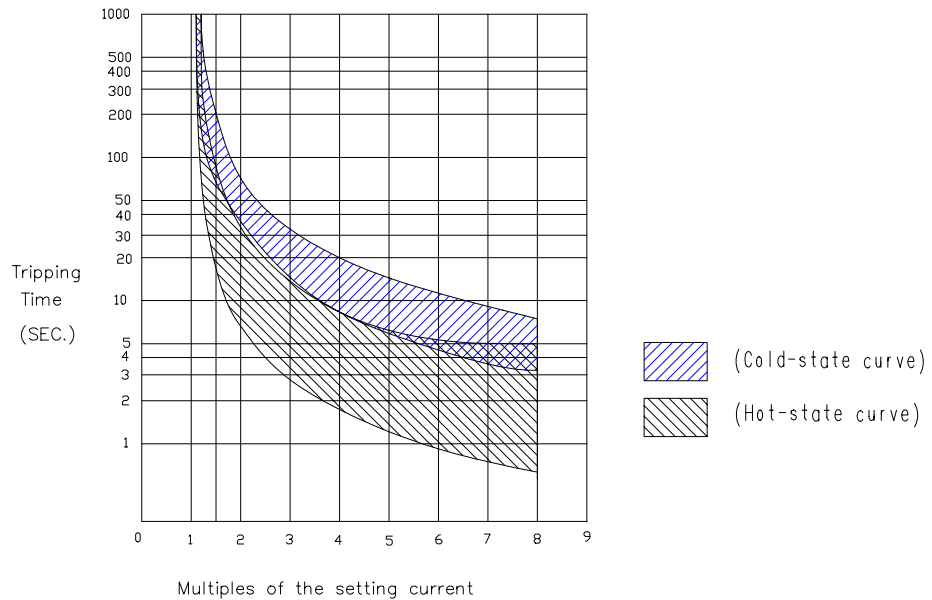

Three-Phase Protection Characteristic

Catalogue Number	RHN-5/0.67A
Current Designation (A)	0.67
Current Setting Range (A)	0.45~0.67

RHN-5/□ Thermal Overload Relay

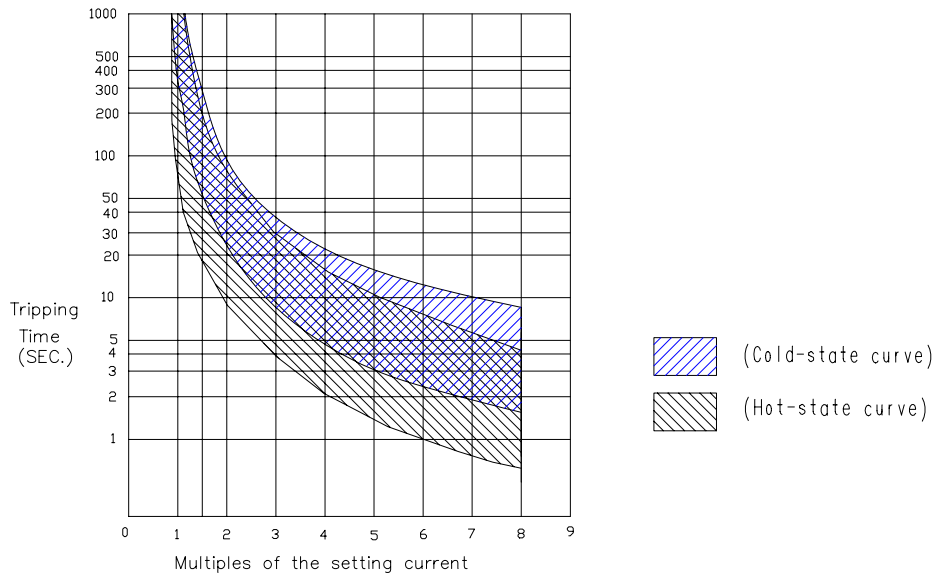

Single-Phase failure Protection Characteristic

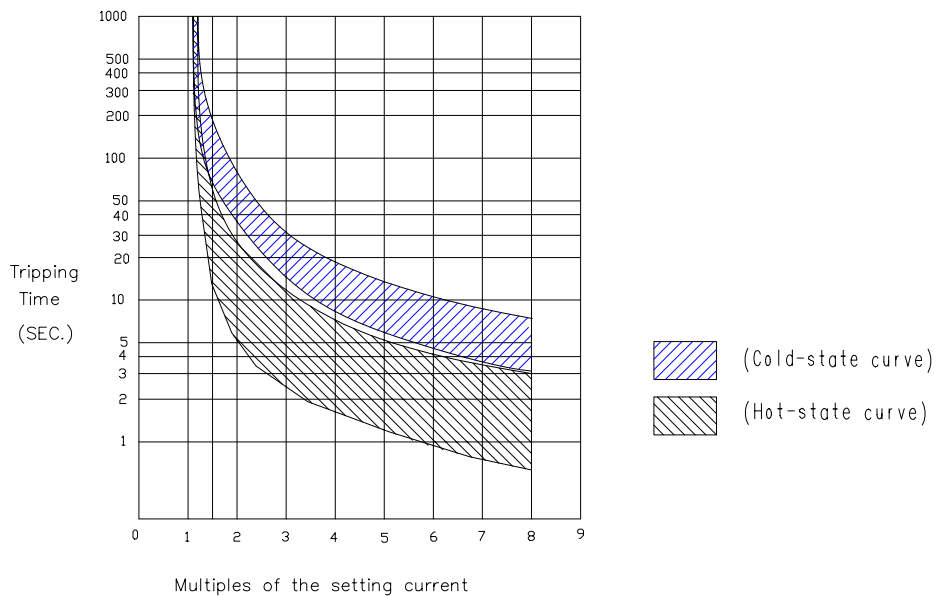

Three-Phase Protection Characteristic

Catalogue Number	RHN-5/1A
Current Designation (A)	1
Current Setting Range (A)	0.67~1

RHN-5/□ Thermal Overload Relay

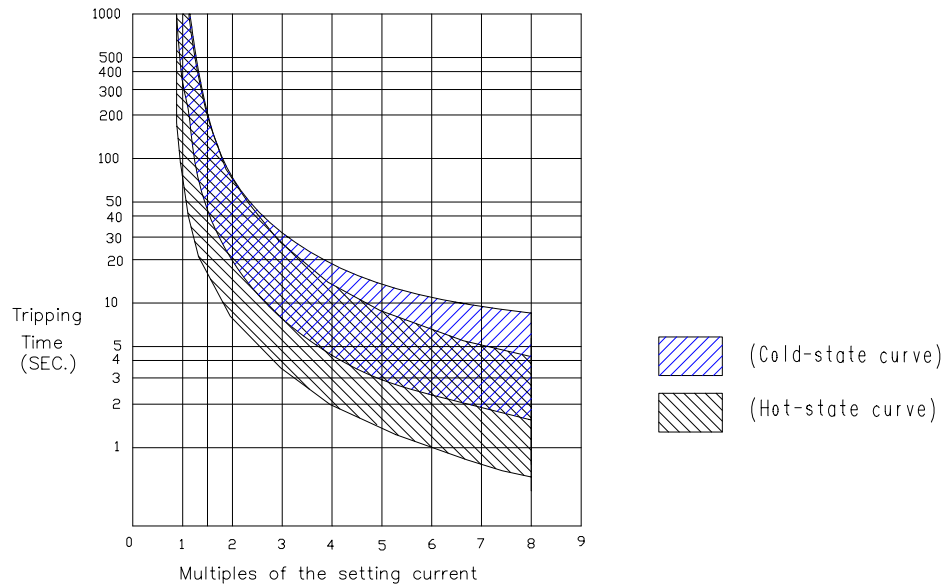

Single-Phase failure Protection Characteristic

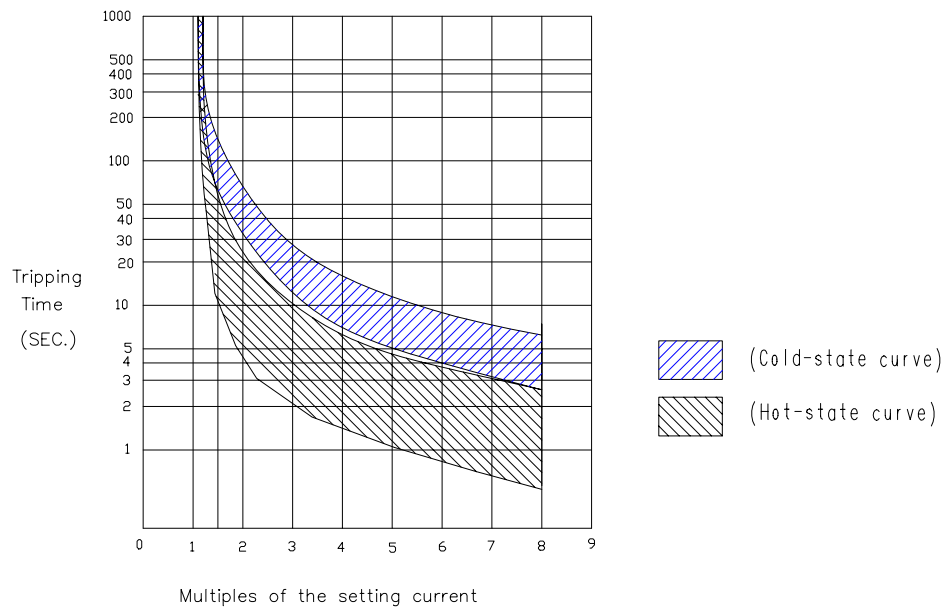

Three-Phase Protection Characteristic

Catalogue Number	RHN-5/1.5A
Current Designation (A)	1.5
Current Setting Range (A)	1~1.5

RHN-5/□ Thermal Overload Relay

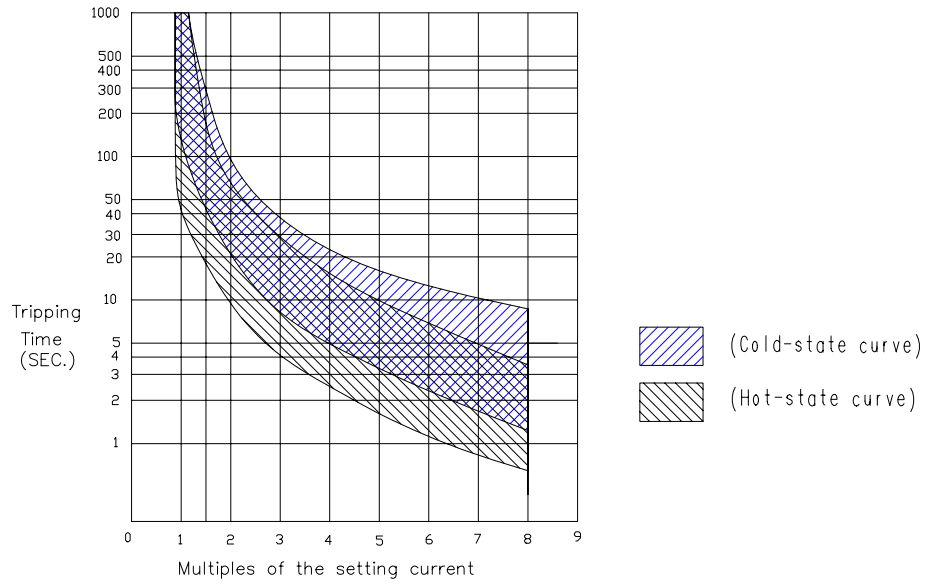

Single-Phase failure Protection Characteristic

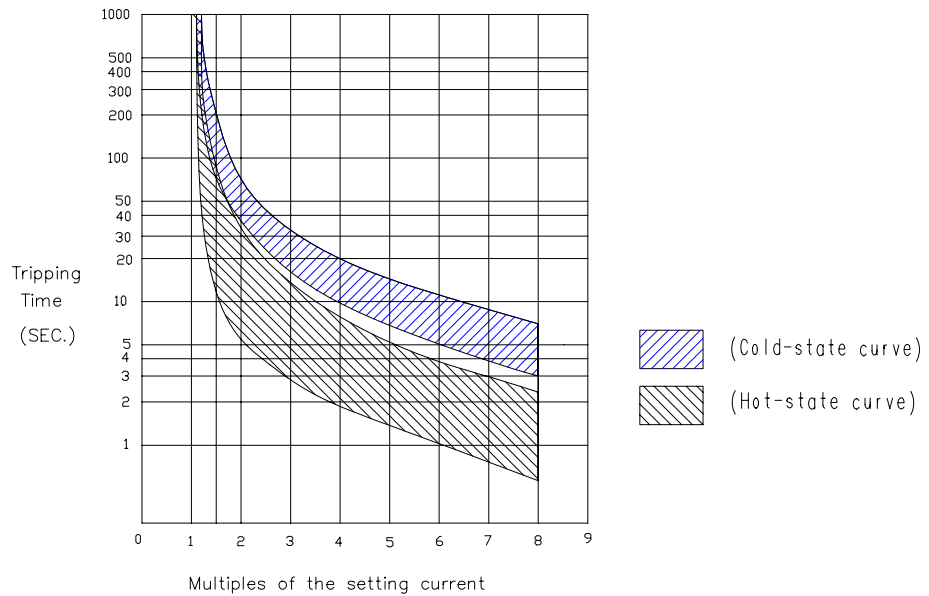

Three-Phase Protection Characteristic

Catalogue Number	RHN-5/2.1A
Current Designation (A)	2.1
Current Setting Range (A)	1.4~2.1

RHN-5/□ Thermal Overload Relay

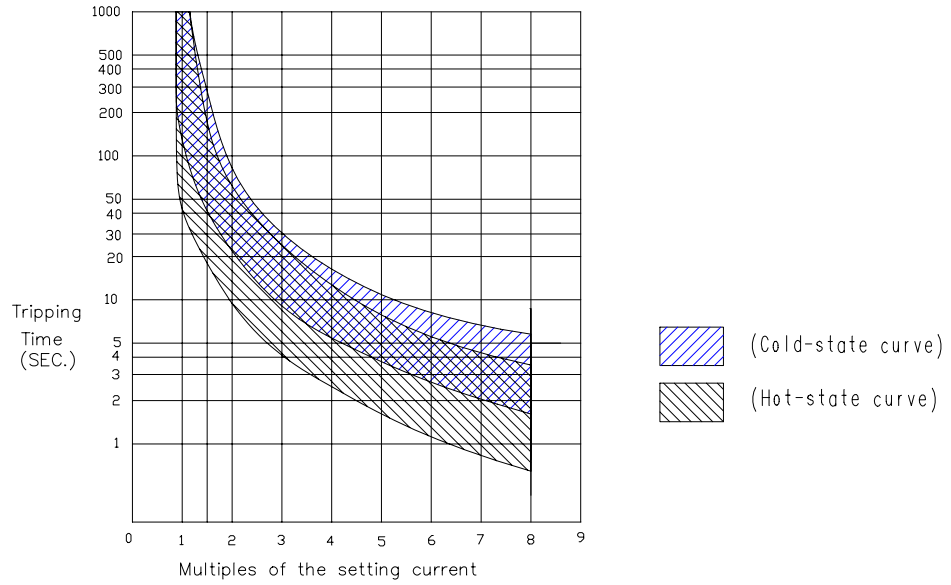

Single-Phase failure Protection Characteristic

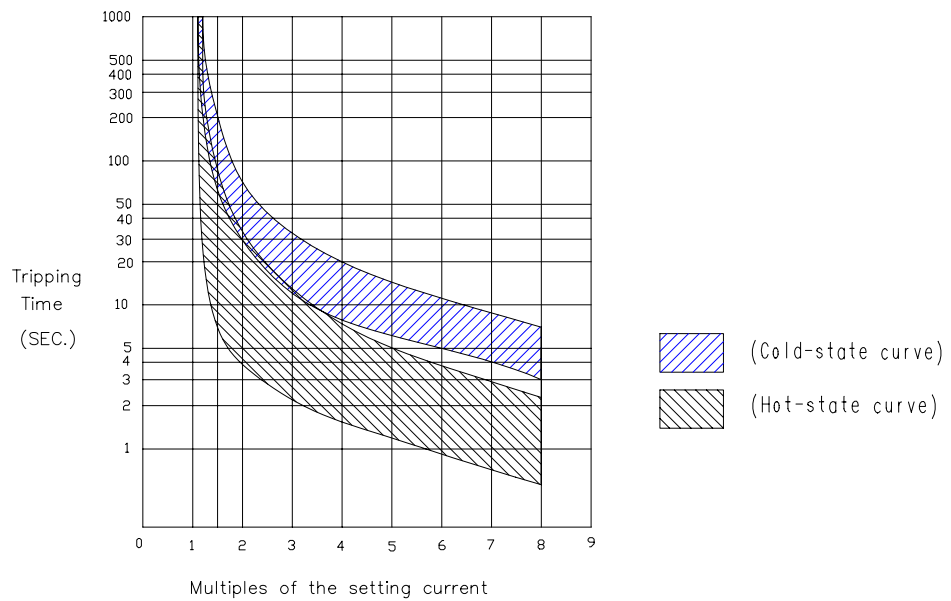

Three-Phase Protection Characteristic

Catalogue Number	RHN-5/2.7A
Current Designation (A)	2.7
Current Setting Range (A)	1.8~2.7

RHN-5/□ Thermal Overload Relay

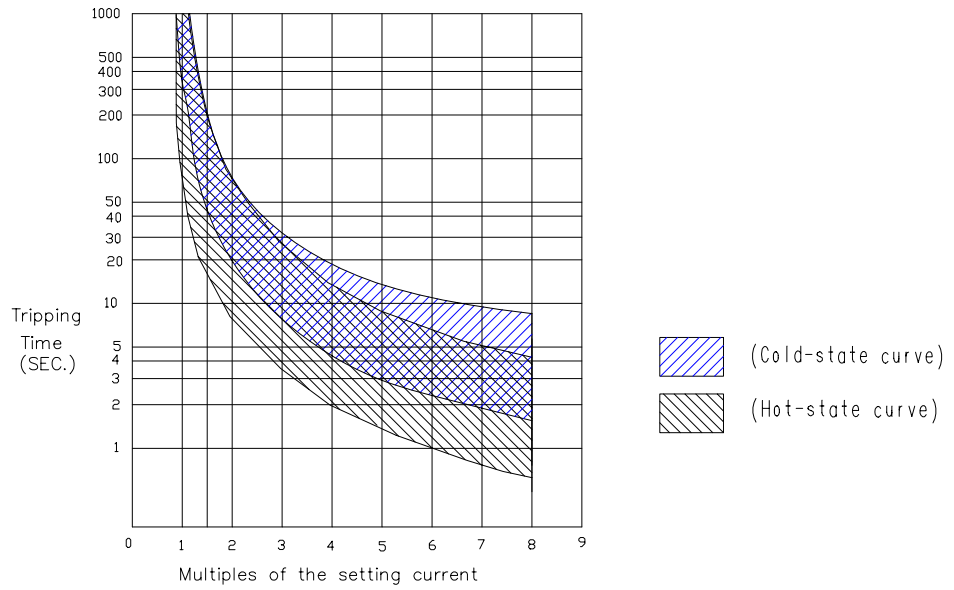

Single-Phase failure Protection Characteristic

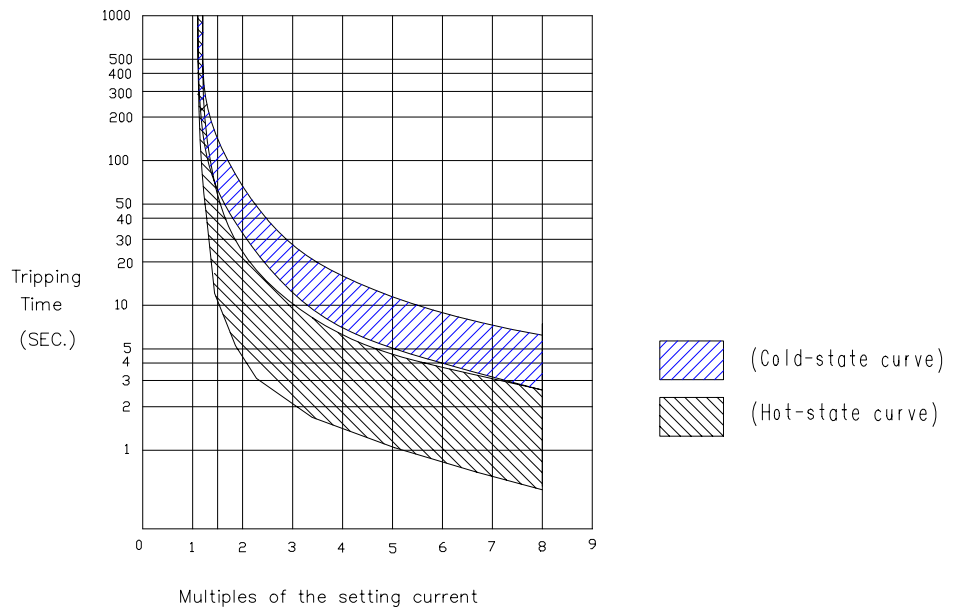

Three-Phase Protection Characteristic

Catalogue Number	RHN-5/3.6A
Current Designation (A)	3.6
Current Setting Range (A)	2.4~3.6

RHN-5/□ Thermal Overload Relay

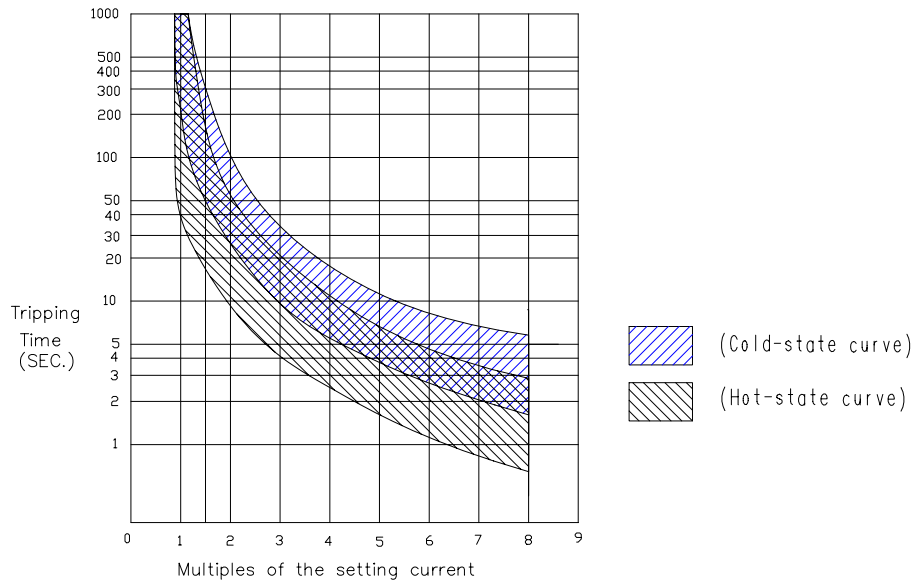

Single-Phase failure Protection Characteristic

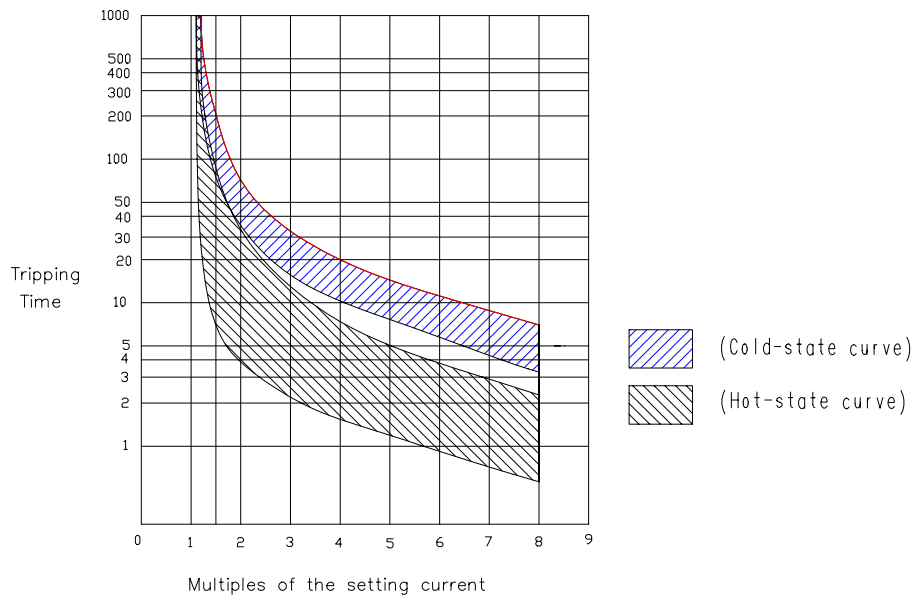

Three-Phase Protection Characteristic

Catalogue Number	RHN-5/5A
Current Designation (A)	5
Current Setting Range (A)	3.5~5

RHN-5/□ Thermal Overload Relay

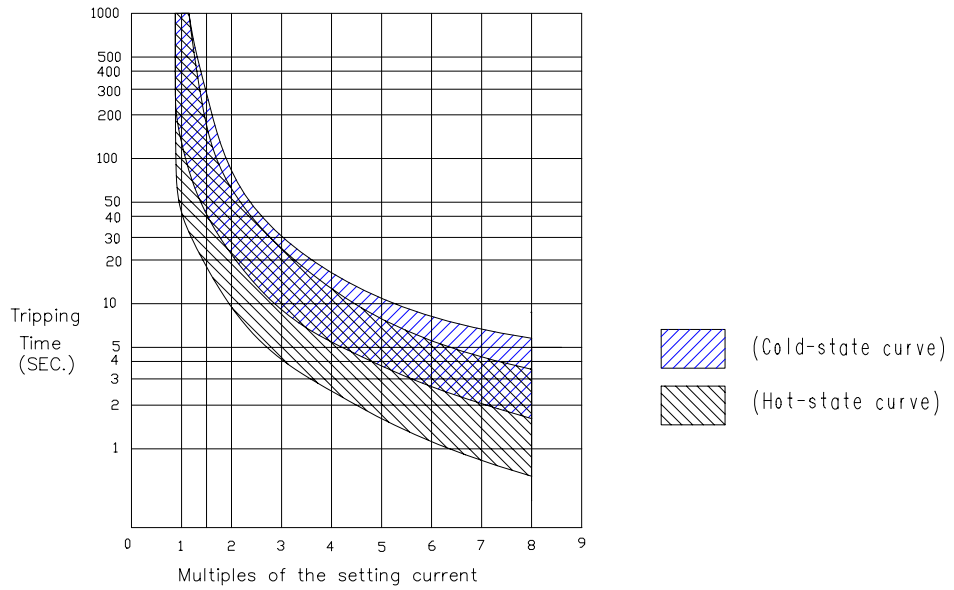

Single-Phase failure Protection Characteristic

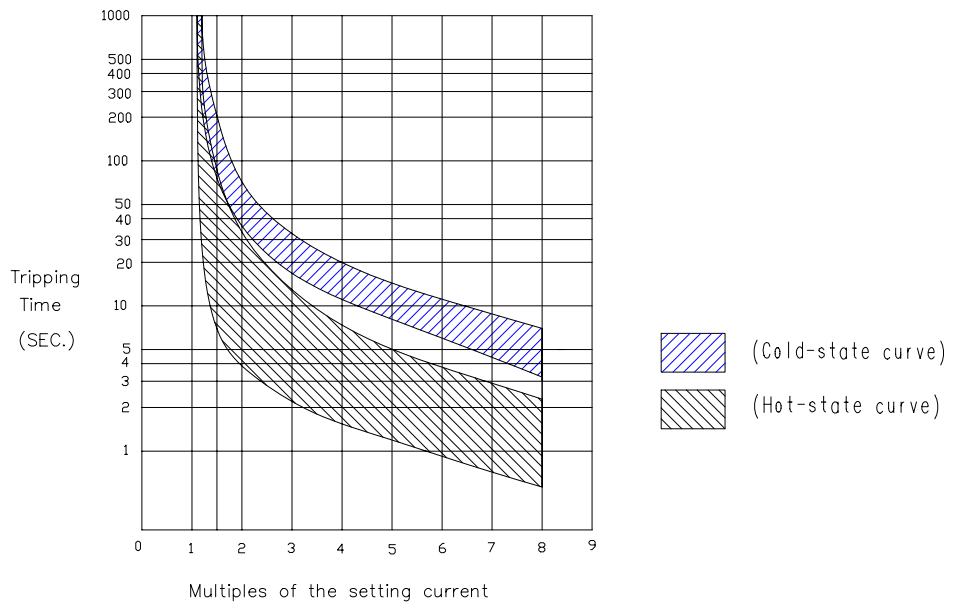

Three-Phase Protection Characteristic

Catalogue Number	RHN-5/6A
Current Designation (A)	6
Current Setting Range (A)	4~6

RHN-5/□ Thermal Overload Relay

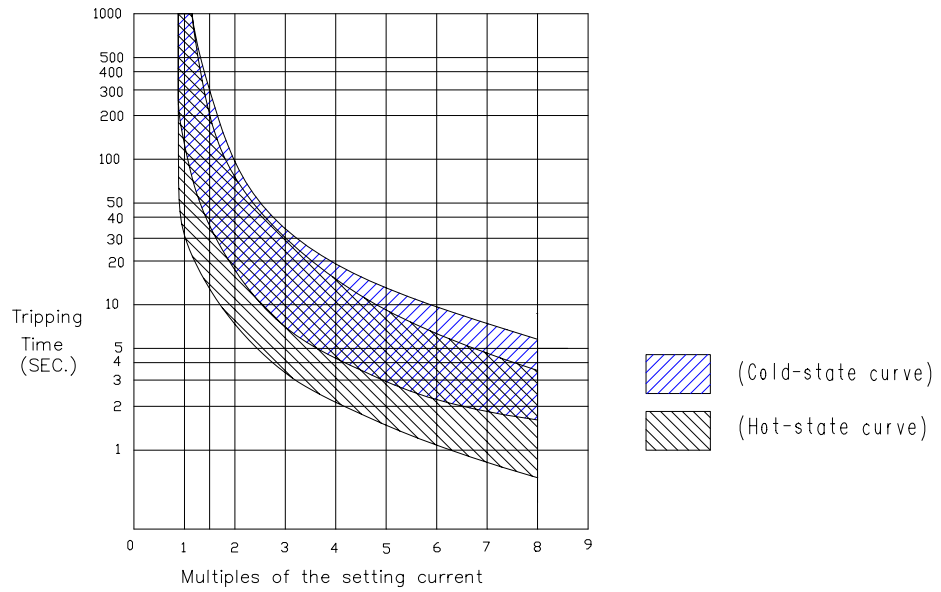

Single-Phase failure Protection Characteristic

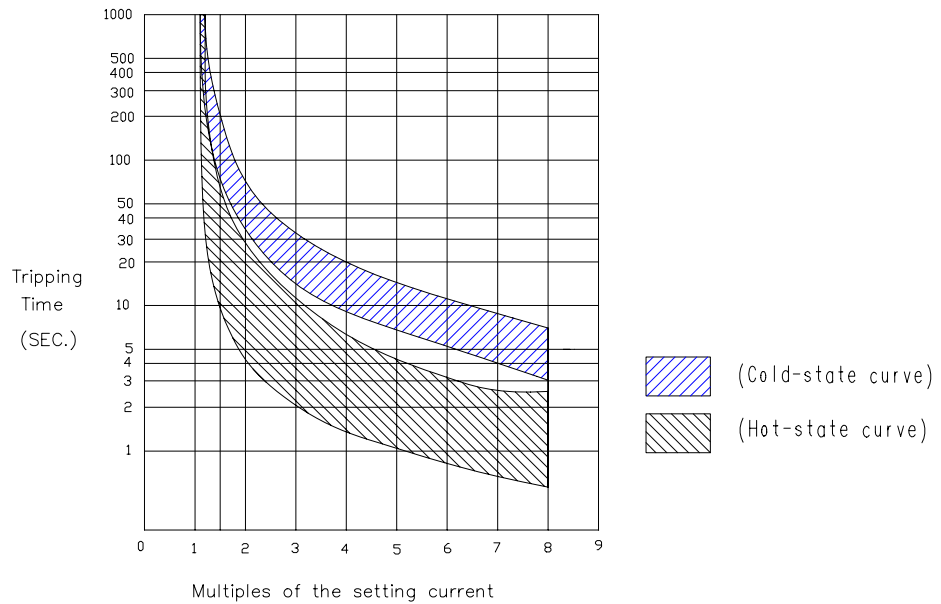

Three-Phase Protection Characteristic

Catalogue Number	RHN-5/8.5A
Current Designation (A)	8.5
Current Setting Range (A)	5.5~8.5

RHN-5/□ Thermal Overload Relay

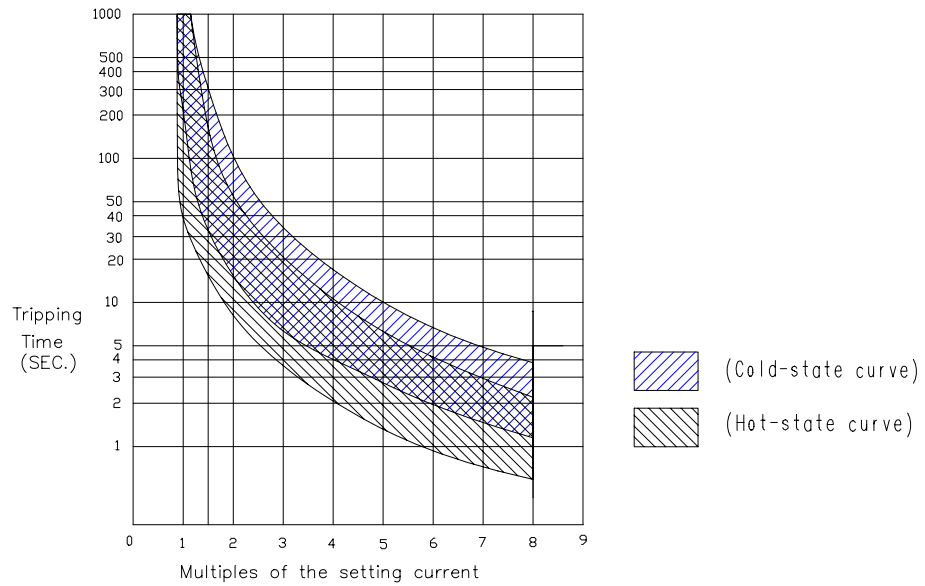

Single-Phase failure Protection Characteristic

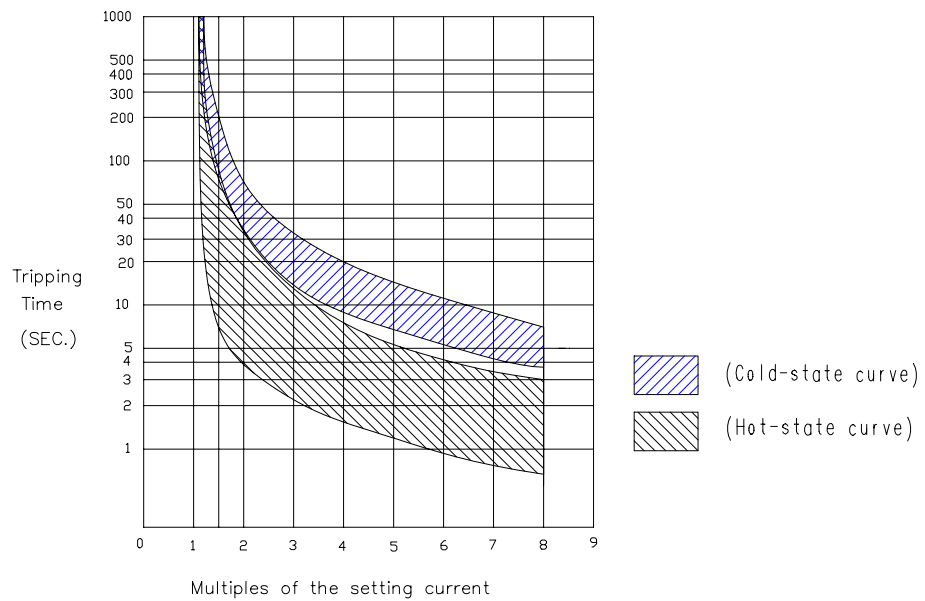

Three-Phase Protection Characteristic

Catalogue Number	RHN-5/12.5A
Current Designation (A)	12.5
Current Setting Range (A)	8.5~12.5

RHN-5/□ Thermal Overload Relay

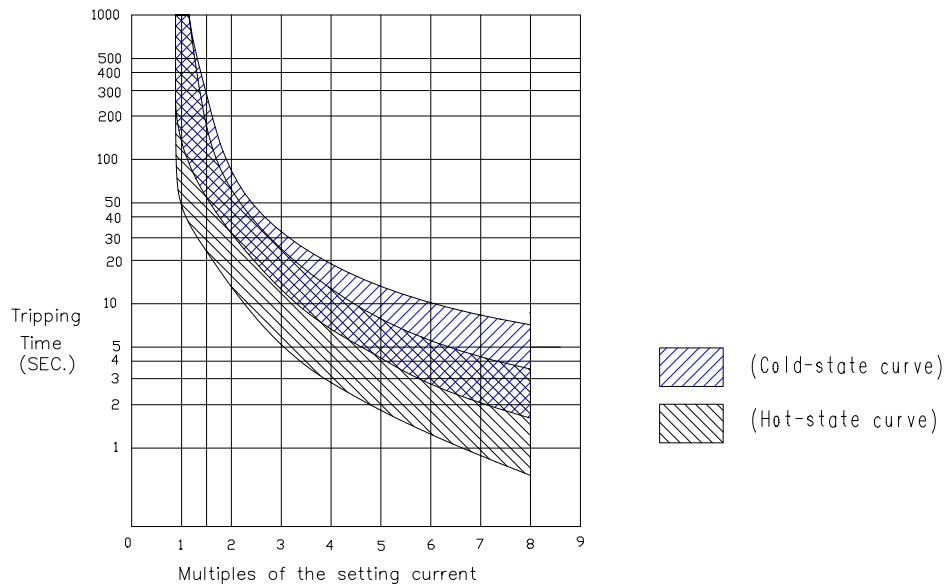

Single-Phase failure Protection Characteristic

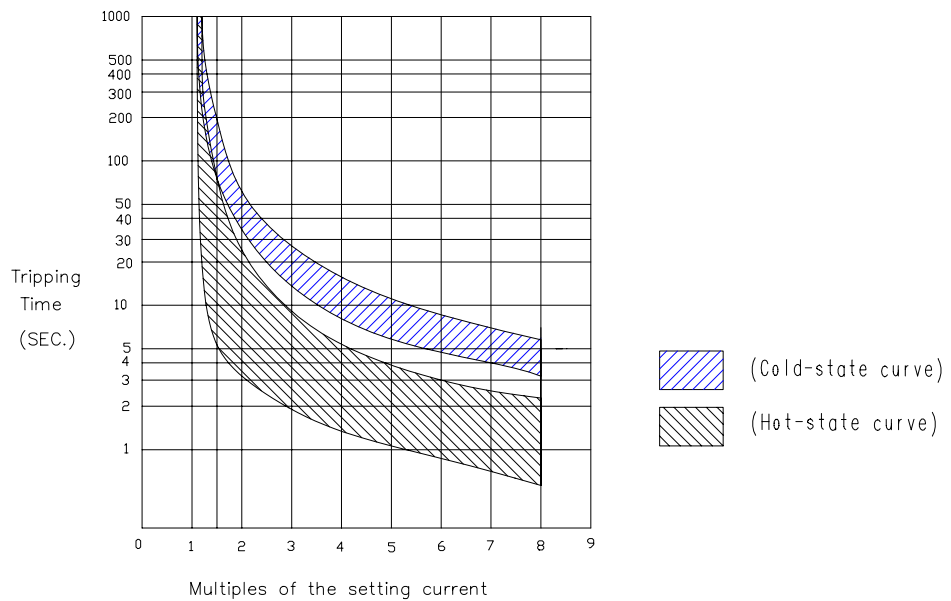

Three-Phase Protection Characteristic

□
5.4. The limit of destruction:

Catalogue Number	RHN-5/0.45A	RHN-5/0.67A	RHN-5/1A	RHN-5/1.5A
Current Designation (A)	0.45	0.67	1	1.5
Current Setting Range (A)	0.3~0.45	0.45~0.67	0.67~1	1~1.5

RHN-5/□ Thermal Overload Relay

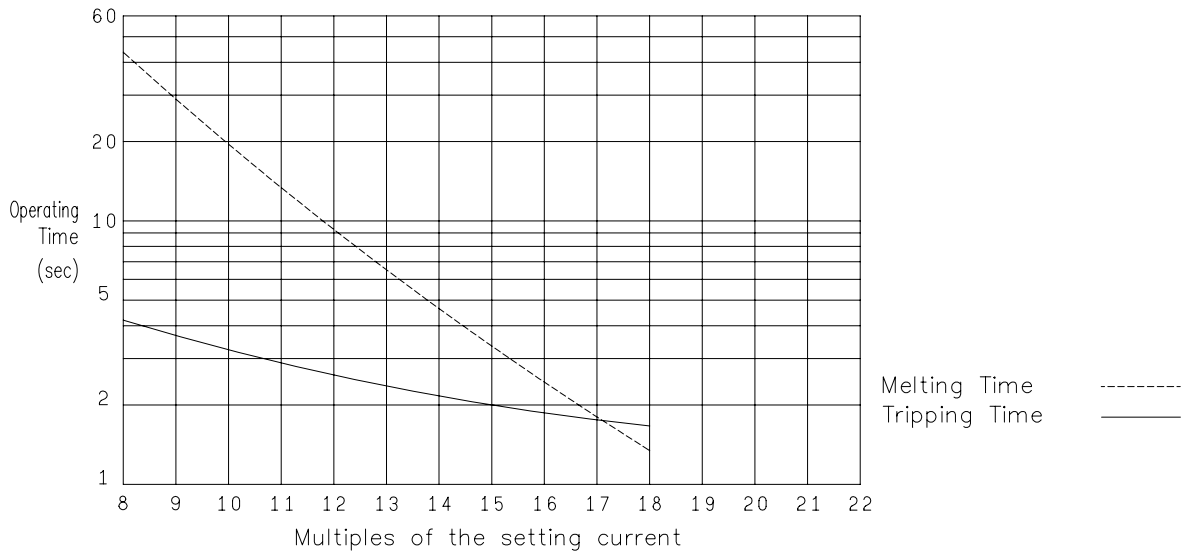

Catalogue Number	RHN-5/2.1 A	RHN-5/2.7A	RHN-5/3.6A
Current Designation (A)	2.1	2.7	3.6
Current Setting Range (A)	1.4~2.1	1.8~2.7	2.4~3.6

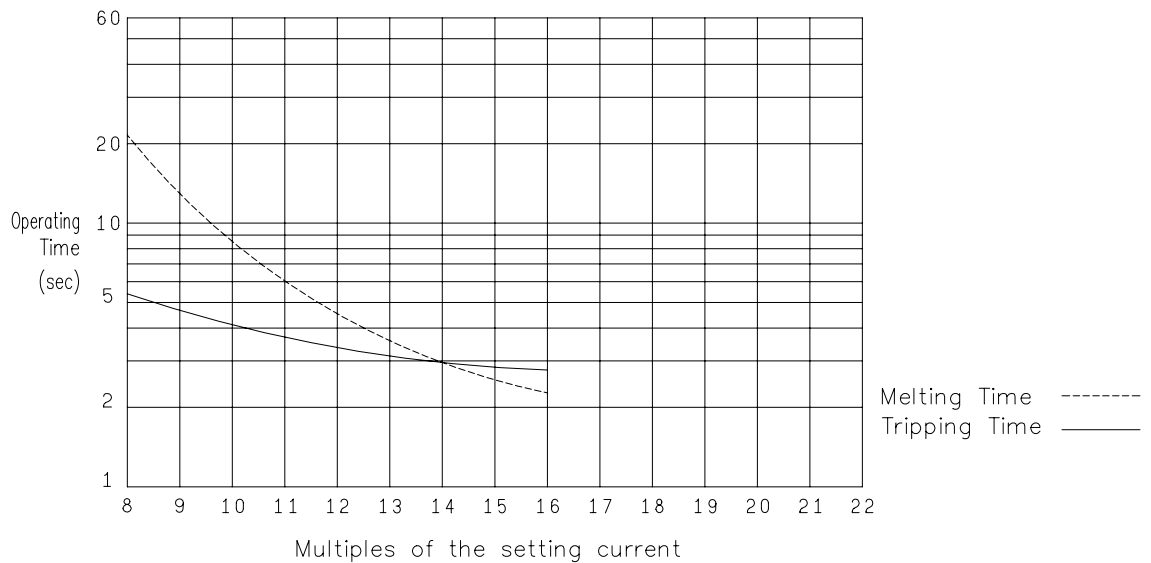

Catalogue Number	RHN-5/5A	RHN-5/6A	RHN-5/8.5A
Current Designation (A)	5	6	8.5
Current Setting Range (A)	3.5~5	4~6	5.5~8.5

RHN-5/□ Thermal Overload Relay

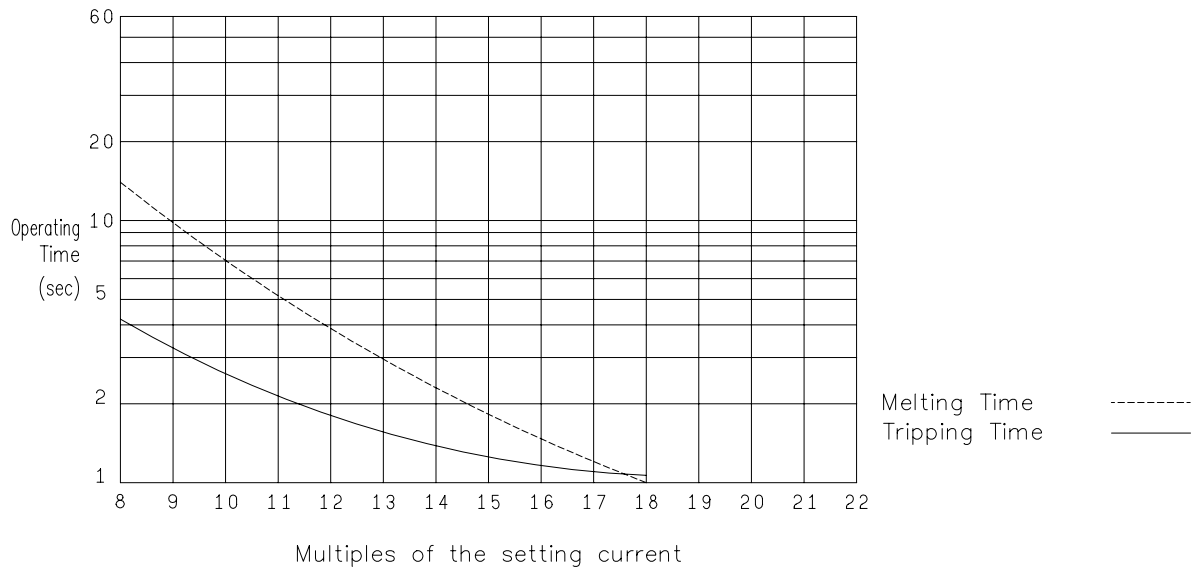

Catalogue Number	RHN-5/12.5A
Current Designation (A)	12.5
Current Setting Range (A)	8.5~12.5

